

## **A new Automated Laboratory Instrument for Soil Water Characteristic Determination.**

### **System Validation at Oregon State University**

K. Vache<sup>1</sup>, J.J. McDonnell<sup>2\*</sup>, C. Graham<sup>3</sup>, J. Ekanayake<sup>4</sup>, T. Davie<sup>4</sup>

1 Institute for Landscape Ecology and Natural Resources, University of Giessen, Giessen, Germany

2 Water Resources Section, Delft University of Technology, Delft, Netherlands.

3 Department of Forest Engineering, Oregon State University, Corvallis, Oregon, USA

4 Landcare Research, Lincoln, New Zealand.

\* on leave from Department of Forest Engineering, Oregon State University, Corvallis, Oregon, USA

#### **Abstract**

The soil water characteristic (SWC) is a fundamental descriptor of soil water retention properties.

While tension table apparatus for defining drainage curves in the near-saturated region (0 to -100 cm H<sub>2</sub>O) has been available for many decades, there has been little advance in automating the process, particularly when measurements of wetting, drying are combined.

We describe a new automated tension table apparatus (the Equi-pF), that uses a precision water flow measurement coupled with an accurately controlled variable hydraulic head to precisely define the relationship between matric potential and volumetric water content from 0 to -100 cm H<sub>2</sub>O (a range of considerable interest in process hydrological research).

The new instrument automates the process without any disturbance to the soil core and has fully programmable suction steps and equilibration times.

We compare Equi-pF moisture release curve results with published tests for four different grain size mixtures of homogenous silica sands and under different sample height and volume combinations. Our results are consistent with published results ( $r^2$  values range from 0.94 to 0.99) and our tests provide guidance on appropriate core lengths for media characterization.

Results from field samples from well-characterized soils at the HJ Andrews Experimental Forest in Oregon USA are also described. These experiments show both consistent drying behavior and drainable porosity decline with depth in the vadose zone. Overall, the instrument's precision and programmable platform make it a useful tool for estimating soil water storage properties and parameters for use in vadose zone hydrology.

## 1. Introduction

The water retention curve or soil water characteristic is a fundamental descriptor of flow in porous media and a defining measure for prediction of water and chemical flow through the soil (Wraith and Or, 2001).

The SWC function describes the relationship between volumetric water content ( $\theta$ ) and matric potential ( $\Psi$ ) under equilibrium conditions in variably wetted soils (Or and Wraith, 1999).

The SWC function may span the full range of soil moisture conditions, although for water movement during rainfall and snowmelt events, the wet portion of the curve (0 to -100 cm H<sub>2</sub>O) is of most interest as this is when the majority of wetting and drainage occurs.

While a number of equations have been developed to describe the SWC (Gardner, 1958; Brooks and Corey, 1966; Brutsaert, 1968; van Genuchten, 1980), they are all dependent on tunable parameters. As yet there is no universal theoretical basis for relating the parameters in the SWC function to other measurable soil properties, such as texture or bulk density (Hillel, 1998). Therefore, the independent measurement of the SWC is required. These measurements are fundamental to many process hydrological investigations and date back to the development of soil physics in the early 20th Century. Indeed, the standard and most popular method for studying SWC near saturation is to obtain water retention curves using tension table with a hanging water column using the approach of Hains (1930).

The SWC is generally obtained by measuring the soil moisture content of a soil sample at different soil water tensions under hydraulic equilibrium conditions (Klute, 1986). The standard method of obtaining a SWC (also called a pF curve) close to saturation (ie. 0 to - 100 cm H<sub>2</sub>O) is by removing water from a saturated undisturbed soil core using a tension table with a hanging water column.

Despite recent advances in laboratory techniques for measuring soil water content and soil moisture potential (Dane and Hopmans, 2002, Winfield and Nimmo, 2002), researchers still rely heavily on tension table with a hanging water column (Buchner funnel or Hains apparatus, following Haines (1930)). Nevertheless, the use of this traditional tension table technique is tedious, labor intensive and time consuming.

The main technical disadvantages are:

1. Regular monitoring of the outflow to determine the hydraulic equilibrium condition is time consuming and labor intensive,
2. The regular handling of the soil sample to determine the equilibrium moisture contents causes disturbance to the fragile soil matrix that leads to less precise and less representative soil moisture estimation,
3. Removal of the unsaturated soil sample from the tension table disturbs the continuity of the water capillarity between the porous plate and soil by introducing an air layer into the soil. Trapped air leads to poor drainage in the tension saturated water column, which reduces the precision of the moisture release curve

We describe a new instrument that uses a precision water flow measurement coupled with an accurately controlled variable hydraulic head to precisely define the relationship between matric potential and volumetric water content from 0 to -100 cm H<sub>2</sub>O. The new instrument automates the process without any disturbance to the soil core.

Measurements are taken through both the wetting and drying cycles based on fully programmable suction steps and equilibration times. The objectives of this report are to:

- Describe the new automated moisture release curve approach
- Compare moisture release curves developed with the approach against:
  1. published lab media results for four different homogenous laboratory silica sand size fractions
  2. published field soil data from 452 soil cores from the HJ Andrews Long Term Ecological Research (LTER) site
- Utilize the automated nature of the device to help outline issues related the development of SWC

The apparatus presented here overcomes the disadvantages of the standard approach by coupling the concept of a hanging column to a microprocessor that automates the timing, measurement and physical set up necessary to develop the drainage curve.

It has the added capability of measuring the wetting cycle allowing study of hysteresis effects on an undisturbed soil sample.

## 2. The Equi-pF Apparatus

The Equi-pF uses the tension table approach to closely approximate a naturally draining saturated soil column. For a given soil sample, the total capillary resistance of the matrix is mobilized against drainage at equilibrium under a given water table or known tension. Since the moisture gradient and the tension gradient across the short soil column are low during the experiment, the measured values closely represent the average tension and moisture content across the soil column.

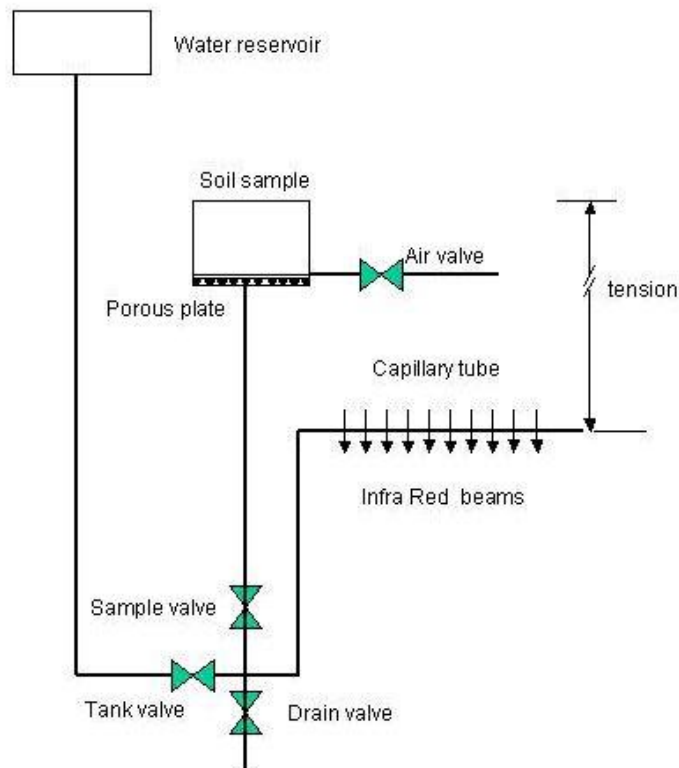

**Figure 1. Components of Equi-pF**

The hanging water column within the Equi-pF is constructed by attaching a horizontal capillary tube to the lower end of a hanging water column that extends downward from a 1 bar high-flow ceramic porous plate (Figure 1).

The upper end of the hanging water tube is connected to one end of a spiral-shaped channel inside the sealed water reservoir beneath the ceramic porous plate.

The other end of the spiral-shaped channel is open to the atmosphere through a valve (air valve in Figure 1).

The air valve and the spiral-shaped channel under the bottom surface of the porous ceramic plate facilitate the expulsion of trapped air during purging.

The horizontal capillary tube is positioned relative to a preferred reference point for application of a known tension to the soil sample.

The reference point can be defined anywhere between the upper surface of the porous plate and the top surface of the soil sample sitting on the porous plate. Such flexibility in defining the reference point allows for more realistic simulations of a draining soil column in the field.

Water movement to and from the soil sample for the applied tensions are measured when the water meniscus in the capillary tube travels through a series of infrared (IR) light beams at regular intervals (Figure 1). The IR light system is the electronic eye by which Equi-pF continuously monitors and measures water movement. The resolution of the outflow volume measurement is 0.1 ml, which can be changed by using a different internal diameter capillary tube and changing the spacing between IR beams.

The de-aired water needed for purging, saturating and wetting the soil sample is stored in the overhead reservoir and controlled by the "tank" valve (Figure 1). This water is open to the atmosphere through a small outlet in the lid. Since the Equi-pF does not use electrically powered pumps to create hydraulic head to operate, the overhead tank is positioned above the soil sample to confer enough hydraulic head for the water to move through the tubes and the porous plate under gravity. With the Equi-pF, a soil sample transitions through four cycles to complete a normal SWC:

1. Purging
2. Saturating
3. Drying
4. Wetting (optional).

Operation of each cycle is controlled by a microcontroller that positions the horizontal capillary tube at the required height relative to the reference point and operates four solenoid valves that direct the movement of water in the system.

### **2.1 Purging Cycle**

Purging involves removing trapped air from the system so that correct tensions are applied to the sample.

It is performed once for each sample-run.

The measuring capillary tube is raised to the highest limit and water from the overhead tank is allowed to flow through the hanging tube, measuring tube, across the bottom face of the porous plate and through the air valve to remove trapped air.

### **2.2 Saturating Cycle**

After the purging cycle a soil sample can be placed on the porous plate.

The Equi-pF automatically saturates the sample by wetting from the bottom under a hydraulic head equivalent to the sample height. To speed this wetting process, soil samples may be saturated manually outside the apparatus. Externally saturated soil samples may be moved to the instrument to complete the final saturation.

The measuring tube is positioned at the top surface level of the sample and fills with water from the overhead tank. This volume of water is then allowed to move into the soil sample and then the emptied measuring tube is re-filled.

This procedure is repeated until the intake rate approaches a user defined equilibrium condition, which is defined as a time limit given for the soil sample to take up 0.1 ml.

### 2.3 Drying Cycle

Water is removed from the soil sample during the drying cycle through a series of tension steps.

To accomplish this, water is allowed to flow from the soil sample through the porous plate and into the measuring tube.

The volume of water is measured as the meniscus passes across the IR light beams. Once filled, the microcontroller then drains the measuring tube by closing the sample valve and opening the drain valve.

This is repeated until the tension within the soil is equivalent to the tension imposed by the hanging column, and water stops flowing. An equilibrium time limit is again used to define this condition.

The column then moves to the next tension step and the process is repeated.

### 2.4 Wetting Cycle

An option is available for the soil sample to follow a wetting cycle after a drying cycle by allowing the sample to take water in from the measuring tube.

In this case, the soil sample is allowed to take water in under the same tensions but in reverse order to the drying cycle. The volume of water entering the soil at each tension step is again measured automatically.

The outflow curve is similar to that shown in Figure 2.

The automated nature of the ~ device is designed to provide data to further explore the relationship between tension and water content through the development of any number of additional scanning curves.

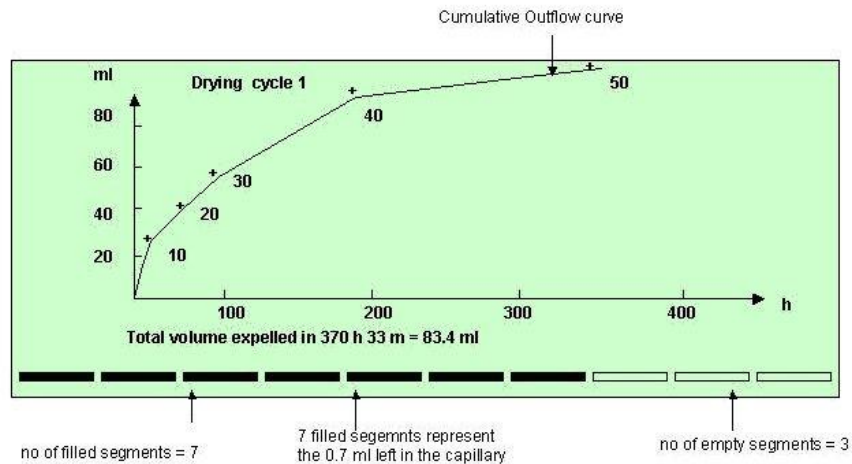

**Figure 2. Current progress of a sample run on the Equi-pF is displayed as a cumulative outflow curve. The total volume expelled since the start of the experiment is shown. A similar outflow curve can be displayed for the current tension step as volume out/ln against time.**

## 2.5 Control System

All operations are controlled by a standalone programmable micro controller.

Outflow time series data are recorded at a resolution of 0.1 ml in non-volatile memory.

Two software modules have been designed to estimate the SWC:

- Control software and
- Data analysis software.

A graphical user interface runs on a Microsoft® Windows® based PC and allows the user to configure the on-board micro controller of Equi-pF with a RS232 interface (Figure 3).

The software interface also allows manual control of all the valves and movement of the capillary tube.

**Equi-pF Automated Moisture Release Curve Apparatus**

**Enter new parameters**

Wetting and Drying Cycles

Number of suction steps: 8

Number of drying & wetting cycles: 2

Time limit for saturation process: 40

No wetting cycles  Wetting cycles

Suction & Equilibrium Time Limits

Sample height cm (0 to 10): 5

Sample No: (0 to 254): 1

Step No	Suction (cm)	Time Limit
1	2	30
2	4	30
3	6	40
4	8	40
5	10	40
6	12	40
7	25	40
8	30	40
9		
10		

Buttons: Setup Ports, Wake up J&J, Program, Quit

**Current parameters in J & J**

Wetting and Drying Cycles

Number of suction steps: 8

Number of drying & wetting cycles: 2

Time limit for saturation process: 40

Wetting Cycles On

Suction Equilibrium time limits

Time Now: 2004/11/22 10:16:10

Started Time: 2004/11/21 13:24:00

Sample height (cm): 5

Sample No: 1

Step No	Suction (cm)	Time Limit
1	2	30
2	4	30
3	6	40
4	8	40
5	10	40
6	12	40
7	25	40
8	30	40
9		
10		

Buttons: Manual Control, Get Data

Current Volume: [ ]

No. Records: 19

Figure 3. Windows based graphical user interface with programmable parameters to configure the Equi-pF to complete up to 10 dry-wet cycles. Window on the right side displays the current parameters being used by the Equi-pF. Window on the left displays the new parameters to be entered to the Equi-pF.

## **2.6 Programming Parameters**

Typical run parameters can be adjusted through the software interface (Figure 3).

In this example, ten tension steps from 10 to 100 cm, in 10 cm increments, are used.

Time limit equilibrium times for each tension step are also shown. It is logical that a shorter time limit is used at the lower soil tensions, though some experimentation may be necessary to define these equilibrium time steps appropriately.

If the outflow curve approaches zero, the current step can be manually bypassed.

Equilibrium conditions are determined by monitoring the time taken for the water meniscus to move between two segments (0.1 ml). If the water meniscus does not move through one segment within a specified time limit, then it is assumed that the soil sample has come to hydraulic equilibrium under the applied tension.

An example of this equilibrium condition is shown in Figure 2.

## **2.7 Data Analysis**

Once the experiment is complete, stored results are transferred directly to a connected computer.

The final step in the analysis is to measure, through oven drying, the amount of water remaining in the sample.

Data are analysed and the water retention curves are plotted automatically for the soil sample once the volume of water remaining in the sample and the dry soil weight are known.

### 3. Results

A set of evaluative tests were developed to outline instrument function and verify that the instrument acceptably reproduces 0 to -100 cm SWC developed through traditional means for a variety of different materials.

#### 3.1 Comparison with Published Accusand SWC

Initial tested was developed using 4 grades of commercially available silica sands (Accusand, Unimin Corp., New Canaan, CT).

This laboratory sand has been well characterized by Schroth et al. (1996), including the development of drainage curves.

The Equi-pF results were evaluated against these data for 12/20,20/30,30/40, and 40/50 sieve size sands (see Table 1) for both 2 and 6 cm depth cores.

Sand grade	12/20	20/30	30/40	40/50
Particle diameter (cm)	0.11	0.071	0.053	0.036
Air entry (cm)	7.2	11.2	14.9	22

**Table 1. Approximate particle diameters and air entry values for the four grades of homogeneous silica sand.**

In all cases the results from Schroth et al. (1996) are well reproduced, both in terms of the location of inflection points as well as the estimated water content across the 0 to -100 cm tension range (Figure 4).

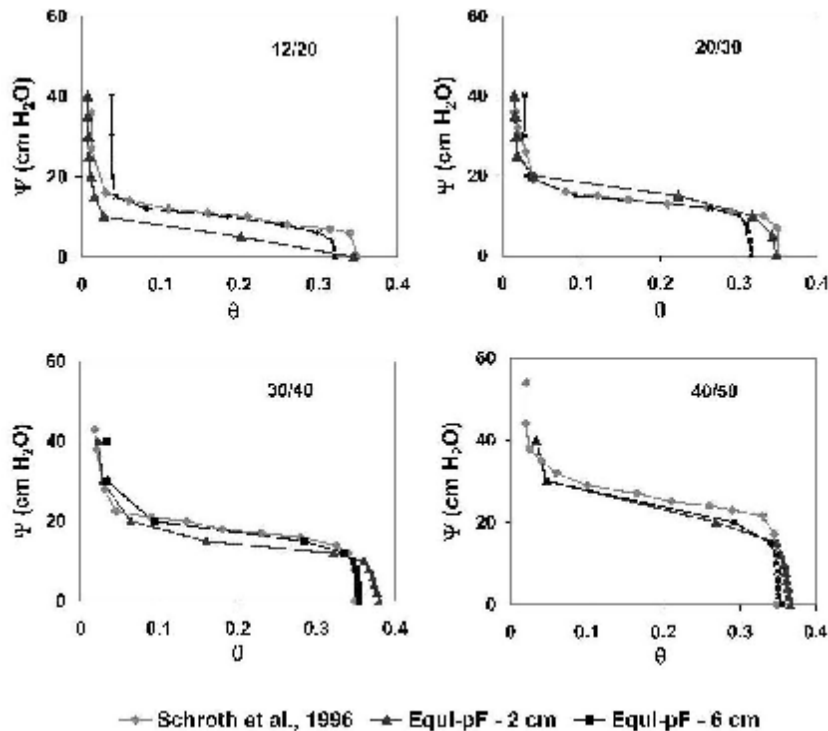

**Figure 4. Equi-pf measured drying water retention curves for 2 cm and 6 cm cores, compared with published values from Schroth et al., (1996).**

$R^2$  values comparing the 6 cm Equi-pF results against the earlier measurements are 0.98, 0.99, 0.97, and 0.94 for the 12/20, 20/30, 30/40, and 40/50 sieve sizes, respectively (Figure 5).

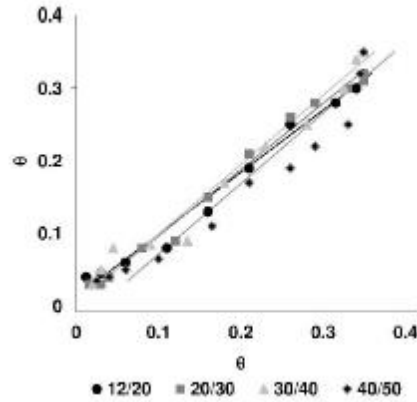

**Figure 5. Comparison plots of water content for results from Equi-pF and Schroth et al., (1996). Results from the Equi-pF were interpolated to match the original tension steps utilized by Schroth et al., (1996). Fitted regression lines are included to aid in interpretation.**

While some variation is evident, the Schroth et al. (1996) results are generally bracketed by the Equi-pF results for 2 and 6 cm core lengths, suggesting that physical set up of the cores, for example the height of the sample, as discussed later, rather than methodological differences may explain the differences.

Figure 6 depicts the full pF curve developed for three of the sands.

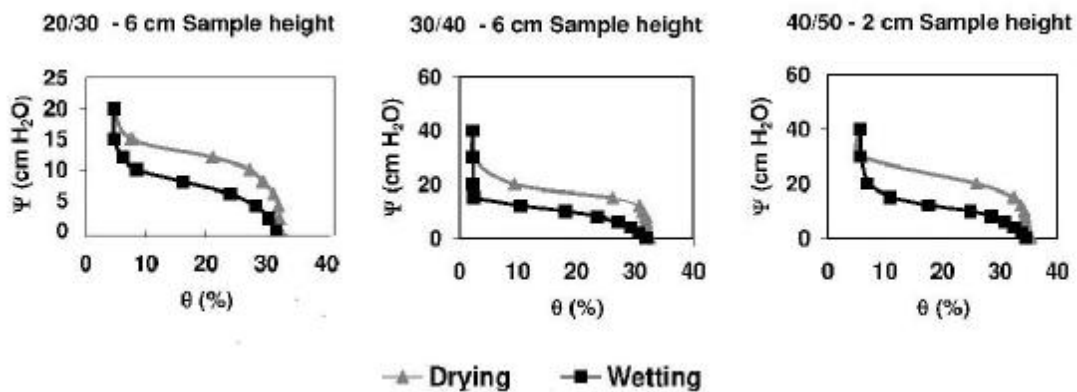

**Figure 6. An example set of Equi-pF wetting and drying curves for the homogeneous sand material.**

### 3.2 Operation on field cores

While the tests utilizing well characterized homogenous sands represent useful indicators of the quality of our methodology, comparisons of results developed for field soils are also instructive.

In this case we compare results from the Equi-pF for soil cores collected in the spring of 2004 to a large set of data developed from soil cores at the same field site by Ranken (1974). The cores were collected from WSIO in the HJ Andrews Experimental forest (HJA), where soil hydrologic properties have previously been characterized (Dyrness, 1969; Rothacher et al., 1967). The study site is located in the western Cascades of Oregon USA on the northwest ridge of HJ A, where saprolite subsoils have developed beneath residual or colluvial regosol soils that extend the effective soil depths up to 7 meters. The soil type is a Frissel series, which is characterized by gravelly clay loam textures (Ranken, 1974).

A total of 6 samples were collected from 2 soil pits on the south aspect of WS 10. In each pit a sample was collected at 10, 30 and 110 cm depth, resulting in two samples at each depth. These depths were chosen to correspond to the depth distribution outlined by Ranken (1974). Values reported here were developed using the three cores from the first pit.

These results indicate a close correspondence between the SWC developed using our methodology and the historical data (Figure 7). Our results for the 10 cm core fall outside of the range of values of the historical data at higher tensions. Nevertheless, given potential differences in natural variability given different collection procedures, as well as researcher traffic and forest operations over the intervening 30 years, we believe these differences to be within the plausible range of variability. Further tests using a larger number of cores may be useful in further establishing the range of variability that currently exists at this site.

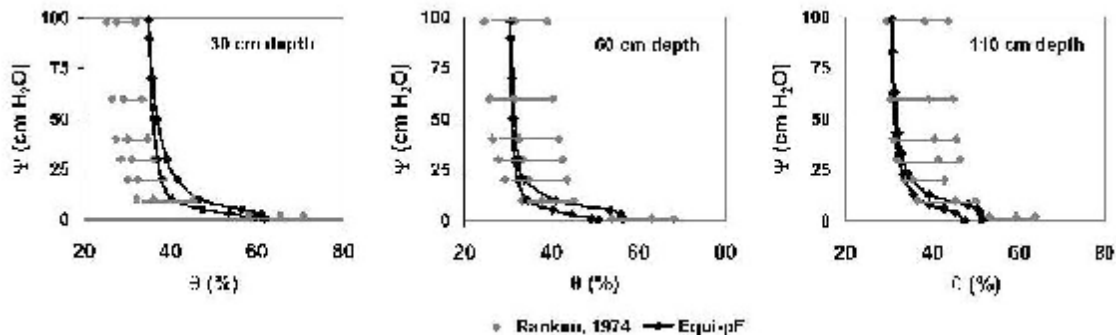

**Figure 7. Equi-pF water retention curves for HJA cores compared with range of data developed by Ranken (1974). The bars represent the minimum, mean, and maximum water contents calculated by Ranken (1974) for each of the tension steps, and are representative only of drying conditions.**

#### 4. Discussion

While we argue that the automation provided by the Equi-pF advances our ability quantify the SWC, our testing raised a number of issues regarding SWC measurement in general, which have bearing on the use of the proposed methodology.

##### 4.1 Reference point

The interface between the soil core and the ceramic plate is the usual reference point to apply suction to a soil sample resting on a tension table (McKenzie et al., 2002; Dane and Topp, 2002).

We used the fidelity of the automated Equi-pF to examine the effect of reference point placement on measured SWC. In this case, two drying curves were developed on an initially oven-dried sample, using a different reference point for each curve. After completing the first curve, the second curve was measured with a second reference point, and without going through a new purging cycle. For both sample runs, initial saturation proceeded with the capillary tube set at the top of the soil sample.

Figure 8 outlines water retention curves for 6 cm 30/40 and 40/50 grade silica sand samples with the top and bottom of the samples taken as reference points. SWC for each sample shows nearly identical slopes at any given moisture content, as shown lower plots in Figure 8.

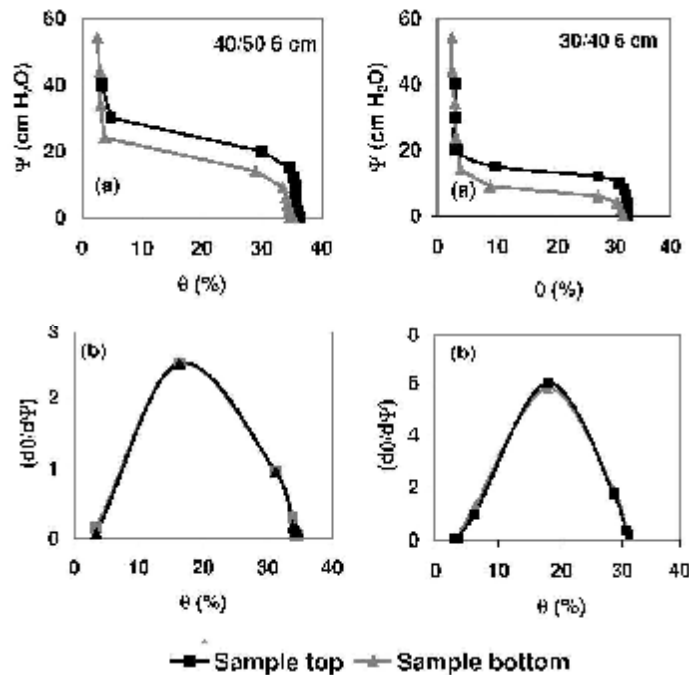

Figure 8. Water retention curves for 6 cm 30/40 and 40/50 grade sand samples with reference points as the top and bottom of the sample. Lower plots are the slope of the water retention curves as change in water content ( $d\theta$ ) per unit change in suction ( $d\psi$ ).

These observations suggest that the reference point location above the sample base does not have a significant effect on the slope of the SWC for these media.

The independence of a reference point may be valid only for sample thickness smaller than, or equal to, the air entry value of the homogenous material. This is because water is not drained from the sample until a suction that is equivalent to the air entry value is applied relative to the top surface of the sample. Under these conditions, the sample will not release water until the water level of the hanging water column drops below the bottom face of the sample. This behavior may not be observed in non-homogenous soils as different portions of the soil tend to release water at different suctions relative a common reference point. However, this discussion suggests the use of thicker samples because they tend to create suction gradient across the sample height and the applied suction does not represent the entire sample. It is also important to note that the absolute values of the suction at a given moisture content changes with the reference point. In our experiments, the air entry value for the largest grain size ( $d = 0.11$  cm) for 12120 silica sand is 7.2 cm. Generally air entry value of the most of homogeneous field soils exceeds 7 cm and may not cause significant problems of selecting a reference point anywhere within the sample height.

#### **4.2 Sample height**

It is a common practice to use sample heights of less than 10 cm for studying soil water retention using tension table, in part because larger sample heights will increase the suction gradient through the sample, and also increase the time necessary to complete the experiment.

For this reason, sample heights around 2 to 3 cm have been suggested as the standard for studying capillary behavior (Dane and Topp, 2002). Others have recommended somewhat larger sample heights (7.5 cm) for studying soil water retention properties using tension table (Mckenzie et al., 2002).

Minimum acceptable sample heights are not generally considered, however full capillary resistance to drainage is less apt to develop .in thin samples, resulting in the potential for an indeterminate air entry value. Since the characteristics of SWC sharply changes around the air entry point, and a large proportion of the water in the soil drains after that point, missing details could have a significant effect on water balance estimation.

We evaluated the role of sample height in development of SWC in an empirical fashion, developing multiple curves using different heights, and evaluating differences between the results.

SWC obtained using the Equi-pF for 2,4 and 6 cm 12120, 20/30,30/40 and 40/50 grade homogenous silica sand samples suggest that < 2 cm sample height could produce inaccurate water retention properties for coarser grained materials. The 2 cm thick 12120 samples failed to produce clear inflection and the air entry details on the water retention curves.

When the sample height was increased to 4 and then to 6 cm, 12/20 SWC converged to a single curve with a clear inflection and air entry feature (Figure 4). On the other hand both 2 and 6 cm samples of all finer grain samples produced a clear inflection and air entry features (Figure 4 - 20/30,30/40 and 40/50).

Comparison of the shapes of the SWC near air entry point between 2 and 6 cm cores suggests that the capillary resistance to water flow is fully mobilized in the thicker samples, but not in the 2 cm 12120 sample. This is evident from the steepness of the SWC before the air entry value for all 6 cm samples, which is not captured for the 2 cm 12120 sample.

The minimum sample height for SWC studies using tension table technique may be defined as "the sample height capable of producing a clear inflection and air entry details on the SWC". This definition is necessary in order to make sure that the complete capillary of the soil matrix is tested, and incorporated in the SWC. Failure to do so will result in an over estimated water content for a given tension step. Our results suggest that for some soils, several sample runs for the same material may be necessary to determine a clear inflection point around the air entry point.

#### **4.3 Equilibration time**

Equilibration time at each pressure head and total run time varied among the different soils, with run time longer in the field samples than in the silica sand.

The sand samples had very short run times, with 10 measurements taken in less than 2 days for the short (2 cm) samples.

The 12/20 sand took a total of 39 hours, with the longest equilibration step taking 18 hours.

The 40/50 sand, on the other hand, took 36 hours, with the longest single step of 16 hours.

The samples taken at the HJA took considerably longer, with the samples running for 5.4 - 7.8 days. Time to equilibrium at each head interval varied considerably, from 4 to 68 hours, depending on the change in water content at that pressure gradient.

## **5. Conclusions**

The SWC is a key component of soil physical descriptions and has significant implications for the wide variety of disciplines that utilize information regarding the water storage and release properties of porous media.

While the tension table apparatus for defining drainage curves in the near-saturated region (0 to -100 cm water) have been available for many decades, there has been little advance in automating these devices. Few devices exist that can combine measurements of wetting and drying.

The methodology outlined in this technical note automates the measurement of water released, or absorbed, by a soil sample under applied soil water tensions.

The Equi-pF automatically saturates the soil sample and measures the volume of water taken up during saturation. The instrument next applies a series of predetermined tension steps, measuring the volume of water released by a soil core at hydraulic equilibrium under an applied tension. Equi-pF calculates automatically the respective SWC of both the drying and wetting cycles. Automating the process for the calculation of SWC increases both the accuracy and reliability of data and process functionality whilst reducing sample disturbance and labor costs.

## **6. Acknowledgements**

We thank Landcare NZ and Jim Herbison (Streat Instruments) for ongoing development support.

This research was partially supported by USDA Forest Service Grant PNW 02-CA-11261930-011. The original design and prototype used in this study was developed by JE.

A commercial version of the Equi-pF device is currently available commercially through Streat Instruments Ltd. Christchurch, New Zealand.

## 7. References

- Brooks, R.H. and A.T. Corey, 1966, Properties of porous media affecting fluid flow, J. Irrig. Drain. Div., Am. Soc. Civil Eng. 93(IR2):61-66.
- Brutsaert, W., 1968, The adaptability of an exact solution to horizontal infiltration, Water Resour. Res. 4:785-789.
- Dane, J.H. and J.W. Hopmans, 2002, Laboratory, In J.H Dane and G.C Topp (ed) Methods of soil analysis, SSSA Book Ser 5. SSSA, Madison. Part 4: 675-692.
- Dane, J.H. and G.c. Topp, 2002, Methods of soil analysis. Part 4, SSSA Book Ser. 5. SSSA, Madison, WI.
- Dyrness, C.T., 1969, Hydrologic properties of soils on three small watersheds in the Western Cascades of Oregon, USDA Forest Servo Res. Note. PNW-II1, 17pp.
- Gardner, W.R., 1958, Some steady state solutions of the unsaturated moisture flow equation with application to evaporation from a water table, Soil Sci. 85:228-232.
- Haines, W.B., 1930, Studies in the physical properties of soil, The hysteresis effect in capillary properties, and the modes of moisture distribution associated therewith, J. Agric. Sci. 20: 97-116.
- Hillel, D. (1998) Environmental Soil Physics. Academic Press, San Diego.
- Klute, A., (ed.) 1986, Methods of Soil Analysis, Vol. 1, 1-1189. Soil Science Society of America, Madison WI.
- McKenzie N., K. Coughlan, H. Cresswell, 2002, The soil water characteristics. P 59-81. In Soil Physical measurement and Interpretation for Land Evaluation. Chapter 4, CSIRO publishing, ISBN 064306767 1, Australia.
- Or, D., and J.M. Wraith, 1999, A new matric potential sensor based on time domain reflectometry, Water Resour. Res. 35:3399-3407
- Ranken, D.W., 1974, Hydrologic properties of soil and subsoil on a steep, forested slope. M.S. Thesis, Oregon State University, Corvallis, 114.
- Rothacher, J., C.T. Dyrness, R.L. Fredriksen, 1967, Hydrologic and related characteristics of three small watersheds in the Oregon Cascades. Portland, OR: U.S. Department of Agriculture, Forest Service, Pacific Northwest Forest and Range Experiment Station. 54 p.
- Schroth, M.H., J.S. Ahearn, J.S. Selker, and J.D. Istok, 1996, Characterisation of Miller-similar silica sands for laboratory hydrology studies. Soil Sci. Soc. Am. J. 60:1331-1339
- Van Genuchten, M., 1980, A closed-form equation for predicting the hydraulic conductivity of unsaturated soils, Soil Sci. Soc. Am. J. 44:892-898.
- Winfield., K.A. and Nimmo., J.R., Controlled liquid volume. In J.H Dane and G.C Topp (ed) Methods of soil analysis. SSSA Book Ser 5. SSSA, Madison. Part 4: 698-704.
- Wraith, J. and D. Or, 2001, Soil water characteristic determination from concurrent water content measurements in reference porous media, Soil Sci. Soc. Am. J. 65: 1659-1666